

Table of Contents

Introduction	3
Specifications	4
Installation	5
Operation	8
Key Functions	8
Backlight On/Off Control & Intensity	8
Display Temperature	8
Display Maximum Temperature	9
Resetting the Max Temperature	9
Setting the Low Temperature Alarm	9
Setting the High Temperature Alarm	10
Turning the Alarms ON/OFF	10
Selecting Degrees F or C	10
Setting the Zero C (32 F) Point	11
Calibrating Temperature	11
NMEA 0183 or External Alarm Output	12
Other CruzPro Products	15
©2000 BV Engineering	PY60MANG
http://www.cruzpro.com	info@cruzpro.com

Other CruzPro Products

- Depthsounders & Speed/Temperature/Log
- DC Volts/Amps/Amp-Hour Monitor
- AC Volts/Amps/Freq/kW Monitor
- LPG/Petrol Gas Detectors/Alarms
- Bilge Water Alarms & Bilge Pump Controllers
- Windlass Controller/Chain Counter
- Digital Fuel Gauge & Fuel Consumption Calculator
- Digital Gauge for Three Tanks /w Separate Alarms
- Smart and Manual Alternator Regulators
- Marine Security System
- RPM/Engine Hours/Elapsed Time Gauge
- Digital Oil Pressure Gauge/Alarm
- Digital Water Temperature Gauge/Alarm
- One and Three Bank Digital Volts Gauges
- Digital Amps Gauge
- Digital Clock/Watch/Race Timers/Alarms
- 8 and 16 Amp Light Dimmers / Motor Speed Controller
- Solar Panel Charge Controllers 6/8/9 & 20 Amps
- 4 & 8 Channel NMEA Combiners/RS-232 Convertors
- Engine/Exhaust Temp. Monitor & Digital Pyrometer
- NMEA 0183 Remote Data Repeater/w 4 Input Channels

Specifications

Power supply: 9.5 to 33.0 VDC, .018 amps nominal

Operating temperature: 32 to 122 F (0 to 50 C)

Size: 61mm dia. x 104 mm (2.5" X 4.1" deep).

Thermocouple: Type J or K

Measurement Range: -20 to 1100 deg C (-4 to 2012 deg F)

Temperature Accuracy: Better than +/- 1 % (front panel adjustable)

Alarms: High and Low temperature settable from 0 to 1100 deg C (32 to 2012 deg F).

Display: 4 digit LCD, 5 levels of backlighting.

Outputs: NMEA 0183 serial data or External Alarm Output (programmable).

whether the display is in degrees F or Degrees C. In the NMEA sentence, *cs is the check sum.

If the External Alarm Output is selected, the output on screw terminal pin B will go high (+4.5 VDC) when an alarm condition exists and the alarms are turned ON. The output will be low (0 VDC) when the alarms are turned OFF or when no alarm condition exists. The output is protected with a 270 ohm resistor, limiting output current from the External Alarm Output to about 15 mA (0.015 Amps).

NMEA 0183 or External Alarm Output

The output on screw terminal pin B is factory set as a digital serial data output at 4800 BAUD (Standard NMEA 0183 format). You can toggle pin B between NMEA and External Alarm Output by pressing and holding both the ▼ and ▲ keys for ten seconds (till you hear the long beep). The selection is automatically saved to nonvolatile memory.

If NMEA 0183 output is selected, the PY60 outputs the standard ASCII integrated instrument transducer sentence on the serial data line at 4800 BAUD.

\$IIXDR,C,xxxxx,C,PY30*cs

xxxxx is the temperature in degrees C, regardless of

Page 12

Installation

Before starting the installation, please read this entire section first. Be sure to install the bulkhead gasket before you install the instrument. Finger tighten the screws that mount the instrument bracket - do not use tools.

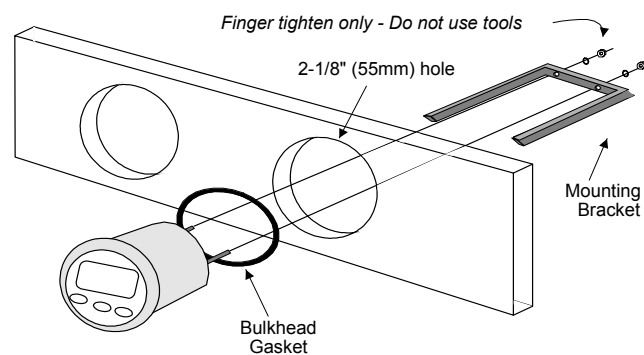

Figure 1

Page 5

Setting the High Temperature Alarm

To set the High Temperature Alarm, press and hold the ▲ key for ten seconds (until you hear a long beep). Use the ▼ and ▲ keys to set the desired value. Press the + key to save the new value to memory.

Turning the Alarms ON/OFF

Press the ▲ key for 1/2 second to turn the alarms ON. Press the ▼ key for 1/2 second to turn the alarms OFF.

Selecting Degrees F or C

To toggle between degrees F and degrees C display, press and hold the ▼ and ▲ keys for 1/2 second while viewing temperature. The instrument will display the characters "F" or "C" for three seconds.

Page 10

- Carefully check all your wiring and if everything is wired correctly you can mount the PY60 in the instrument hole. Be sure the bulkhead gasket is in place and use only finger tension to tighten the bracket hold-down nuts. *Do not overtighten the bracket or you may damage the case - do not use tools to tighten the nuts.*

Thermocouple Installation

The installation instructions for each type thermocouple you can fit to the PY60 is supplied with the thermocouple.

Page 7

- Drill a 2-1/8" (55mm) mounting hole where you desire to mount the instrument (Figure 1).
- Bring the thermocouple wires, ground, and power lines out of the mounting hole and use a small flat screwdriver to make the connections to the screw terminals on the instrument case back as shown in Figure 2.

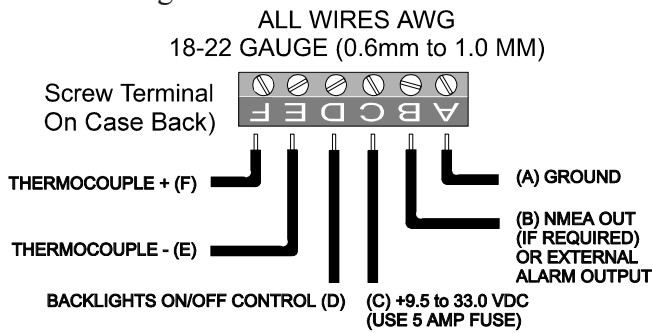





Figure 2

Operation

Key Functions

The    keys are used to select what to display, set backlight levels, calibrate the instrument, and set/activate low and high temperature alarms. New information is automatically saved to memory.

Backlight On/Off Control & Intensity

Switch screw terminal pin D to +12/24V to enable/turn ON the backlights. While viewing temperature, press the  key for 1/2 second to increment through the five different backlight intensities including OFF.



Display Temperature

Press the  key to display temperature.

Setting the Zero C (32 F) Point

Place the thermister probe in a glass of ice water at 32 degrees F (0 degrees C). Wait ten seconds to insure the probe temperature has stabilized. While viewing temperature, press and hold the  key for 10 seconds (until you hear a long beep). The display will show "0" if the PY60 is in degrees C mode, or "32" if in degrees F mode. *Zero the display before calibration!*



Calibrating Temperature

While viewing temperature, press and hold down all three keys for 10 seconds (until you hear a long beep) to calibrate the temperature value. Use the  and  keys to make the value read correctly. Press the  key to save the new value to memory. The factory default is for a type K thermister. The calibration can be used to adjust the temperature reading for type J or K thermisters.





Display Maximum Temperature Memory

Press  key to display the maximum temperature seen by the instrument since last reset. The display will blink to prevent confusion between temperature and maximum temperature

Resetting the Max Temperature

While viewing Max. Temperature, press and hold the  and  keys for ten seconds (until you hear a long beep) to reset the memory.

Setting the Low Temperature Alarm

While viewing temperature, press and hold the  key for ten seconds (until you hear a long beep) to set the Low Temperature Alarm. Use the  and  keys to set the desired value. Press the  key to save the new value to memory.