

Warranty

Each unit is carefully tested and adjusted at the factory before shipping and is warranted for one full year against original defects in materials or workmanship. This warranty does not include damage to the product resulting from accident or misuse.

If the product should become defective within the warranty period, we will repair or replace it free of charge, including free return transportation, provided it is delivered prepaid to the dealer from whom it is originally purchased.

This warranty gives you specific legal rights, and you may also have other rights which vary from state to state, or country to country.

O
W
N
E
R'
S



EFS10/12

Handbook

Warranty

Each unit is carefully tested and adjusted at the factory before shipping and is warranted for one full year against original defects in materials or workmanship. This warranty does not include damage to the product resulting from accident or misuse.

If the product should become defective within the warranty period, we will repair or replace it free of charge, including free return transportation, provided it is delivered prepaid to the dealer from whom it is originally purchased.

This warranty gives you specific legal rights, and you may also have other rights which vary from state to state, or country to country.

O
W
N
E
R'
S



EFS10/12

Handbook

Other CruzPro Products

- DC Volts/Amps/Amp-Hour Monitors
- AC Volts/Amps/Frequency/kW Monitor
- LPG/Petrol Gas Detectors/Alarms
- Bilge Water Alarms & Bilge Pump Controllers
- Windlass Controller/Chain Counter
- Digital Fuel Gauge & Fuel Consumption Calculator
- Smart and Manual Alternator Regulators
- Marine Security System
- RPM/Engine Hours/Elapsed Time Gauge
- Digital Oil Pressure Gauge/Alarm
- Digital Water Temperature Gauge/Alarm
- One and Three Bank Digital Volts Gauges
- Digital Amps Gauge
- 1200 deg C Digital Pyrometer
- Digital Clock/Watch/Race Timers/Alarms
- 8 and 16 Amp Light Dimmers / Motor Speed Controller
- Solar Panel Charge Controllers
- 4 & 8 Channel NMEA Combiners/RS-232 Convertors
- Engine/Exhaust Temperature Monitor/Alarm

See full details at <http://www.cruzpro.com>
Email to: info@cruzpro.com

Page 14

Table of Contents

Introduction	4
Specifications	5
Installation	6
Operation of the EFS-10	10
Maintenance	13
Other CruzPro Products	14
Warranty	Back Cover

©1997 BV Engineering
Ver 1.2

<http://www.cruzpro.com>
email: info@cruzpro.com

Page 3

system RESET, then the Pump On/Off LED will flash three times every five seconds. The maximum number of flashes for the Pump On/Off LED is nine flashes every 5 seconds. To reset the count, hold the RESET key down for three seconds (until you hear a long beep).

The EFS-10 is powerful enough to drive some very large pumps but may overheat if required to do so for very long. If the EFS-10 overheats, it will shut down and rapid flash the Pump On/Off LED to indicate the overheated condition. As soon as the thermal protection circuit senses that it is safe to resume, it will switch the pump back on again (if required).

Page 12

Specifications

Power Supply: 9.5 to 18 VDC, 0.02 amp nominal.

Operating temperature: 0 to 50 deg Celsius (32 to 122 deg Fahrenheit).

Size: 100 x 60 x 30 mm (4 x 2.4 x 1.2 inch).

Alarms: 85 dB at 30 cm (12"), two LED indicators. Output for external 105 dB alarm (LA-20).

Switching capability: 8 amps continuously (larger pumps until thermal protection cuts in).

Thermal protection: Thermal protection automatically resets when cooled and the pump start again, if necessary.

Page 5

Introduction

The EFS-10 Automatic Bilge Pump Controller monitors the presence of water in the bilge of your boat and turns on your pump if the electronic sensor detects water continuously for more than 15 seconds. Once turned on, the pump will run for at least 15 seconds. If the water level does not recede within two minutes, an 85 dB alarm sounds until the water recedes or the ALARM RESET switch is pressed. An LED indicator shows you when the bilge pump is running and how many times it was automatically activated since the last SYSTEM RESET. At a glance you can tell if the bilge pump was running while you were away, and how many times it was activated.

You can also manually activate the bilge pump from the front panel. The EFS-10 can run a pump drawing a total of up to 8 amps continuously, and larger pumps for shorter periods of time. Internal thermal shutdown protects the EFS-10 from overheating when driving large pumps.

Page 4

Maintenance

You should verify proper operation of the EFS-10 on a regular schedule of maintenance to prevent any problems. Wires and connections can corrode and pump housings and seals can leak, causing failure that can prevent proper operation. There is no substitute for periodic maintenance checks.

In addition to verifying proper manual operation, you should check proper operation of the electronic water sensor. The simplest way to check for proper operation is to fill a small container with water and submerge the electronic water sensor for more than 15 seconds. Verify that the EFS-10 switches on the pump. Leaving the sensor submerged for two minutes should activate the alarm.

If necessary, you can clean the stainless water sensor probes with a mild detergent and a rag.

Page 13

Installation

Please read and adhere to the following directions carefully. An error here can cause serious damage which is NOT covered by the warranty. If you are unsure, seek professional assistance. Do not overtighten the screw terminals and watch that no loose strands of wire are free to short against electronic components. Serious damage can result!

Remove the screws that attach the case front to the back. Align the back onto any suitable surface. Using the holes in the case back as a drill guide, mark the location of the two holes with a soft pencil lead. Remove the case back and drill two 2mm (3/32 inch) holes where indicated. Mount the case back using the two countersunk self-tapping screws provided. The case is not waterproof and must be located in a dry location.

Thread a 22 gauge (or heavier) ground wire through the rubber grommet on the bottom of the front case and connect it to terminal T2 as shown in Figure 1.

Page 6

Whenever the water level drops so as to expose the probe, within 15 seconds the pump will turn off and the pump On/Off LED will flash once every five seconds to tell you it had been activated once since the last system RESET. If the pump is automatically activated again, the pump ON/Off LED will flash twice every five seconds, etc.

To clear the flashing LED count, press and hold the **Reset** key for three seconds (until you hear a long beep).

If, while in automatic mode, the water does not recede below the sensor level within two minutes, the alarm will sound.

The alarm will continue to sound until either the water recedes or you press the **Reset** key. Pressing the **Pump On/Off** also turn off the alarm, return you to manual mode, and turn On/Off the pump as well. When the water has receded the Pump On/Off LED will flash the correct number of times.

If the pump has been on three times since the last

Page 11

Operation of the EFS-10

When you connect power to the EFS-10, you should hear a short beep and the "power on" LED should light. To turn on the pump, press the switch labeled **Pump On/Off**. The Pump On/Off LED should light and the pump should be activated. Pressing the switch again will turn off the pump.

To activate the Automatic mode press the **Auto / Manual** switch once. The Auto / Manual LED will light indicating that the pump is being automatically controlled by the EFS-10.

If the sensor detects water for more than 15 seconds, the pump will start. If the probe detects that water is not present, even if for just an instance, the 15 second timer will reset and start over from zero. Once activated, the pump will run for at least 15 seconds. This feature, and the 15 second timer prevents constant cycling of the pumps by a small amount of water sloshing in the bilge.

Page 10

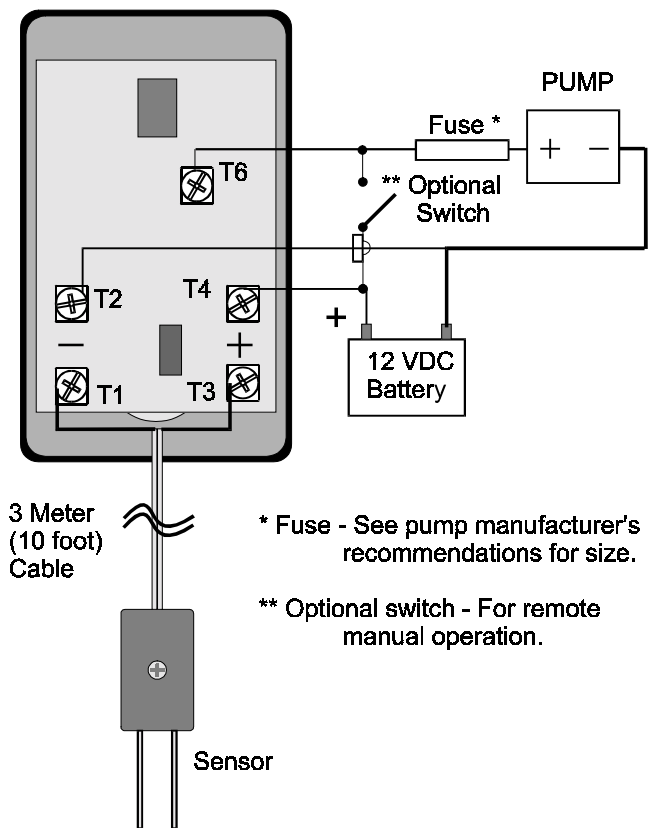

Figure 1
Connection Diagram

Page 7

Operation of the EFS-10

When you connect power to the EFS-10, you should hear a short beep and the "power on" LED should light. To turn on the pump, press the switch labeled **Pump On/Off**. The Pump On/Off LED should light and the pump should be activated. Pressing the switch again will turn off the pump.

To activate the Automatic mode press the **Auto / Manual** switch once. The Auto / Manual LED will light indicating that the pump is being automatically controlled by the EFS-10.

If the sensor detects water for more than 15 seconds, the pump will start. If the probe detects that water is not present, even if for just an instance, the 15 second timer will reset and start over from zero. Once activated, the pump will run for at least 15 seconds. This feature, and the 15 second timer prevents constant cycling of the pumps by a small amount of water sloshing in the bilge.

Page 10

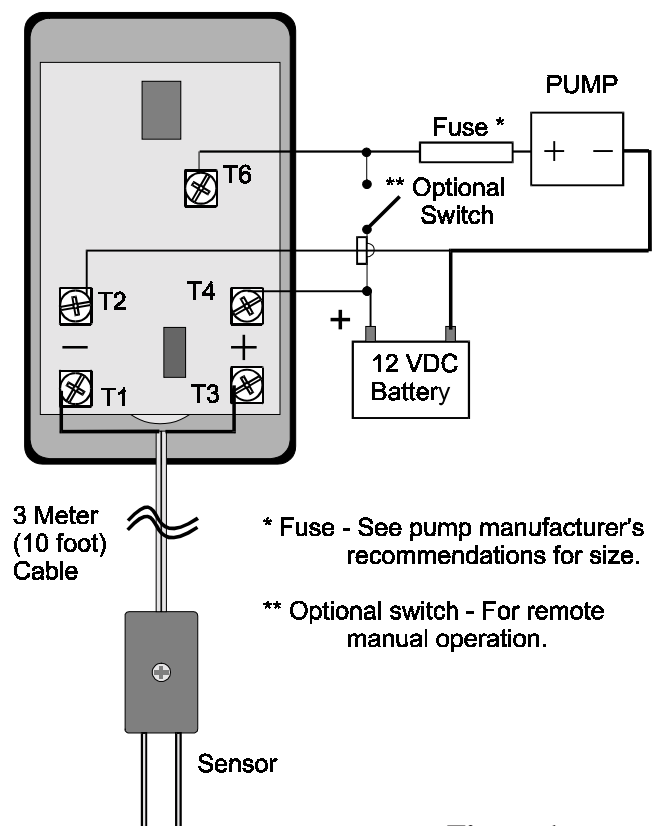

Figure 1
Connection Diagram

Page 7

Thread a suitable size wire (see Table 1) for the +12 VDC battery connection through the grommet and connect to terminal T4 (*do not connect to the battery yet*).

Length From Source to Destination and Back

	3	8	10	15	Meters
	10	26	33	49	Feet
Amps -----					
5A	16	16	16	16	Gauge
10A	16	16	14	12	Gauge
15A	16	14	12	10	Gauge
20A	16	12	12	10	Gauge

**Table 1
Minimum Recommended Wire Size**

Thread a suitable size wire for the pump through the grommet and connect to terminal T6.

Connect the loose end of the ground wire to a common ground point on your boat's distribution panel. Next connect the loose end of the pump wire to the pump through the size fuse recommended by the pump manufacturer.

Install the electronic water sensor in a suitable location in the bilge using the long stainless self-tapping screw provided. The stainless probes should point down. Connect the loose ends of the electronic sensor wires to terminals T1 and T3 (polarity is not important).

Connect the +12VDC wire from terminal T4 to your +12VDC distribution point only after all the other connections have been made and checked carefully. When you make this last connection the EFS10 will beep once and the power-on LED will light. If any changes have to be made, disconnect the +12VDC wire at the distribution point first.

Thread a suitable size wire (see Table 1) for the +12 VDC battery connection through the grommet and connect to terminal T4 (*do not connect to the battery yet*).

Length From Source to Destination and Back

	3	8	10	15	Meters
	10	26	33	49	Feet
Amps -----					
5A	16	16	16	16	Gauge
10A	16	16	14	12	Gauge
15A	16	14	12	10	Gauge
20A	16	12	12	10	Gauge

**Table 1
Minimum Recommended Wire Size**

Thread a suitable size wire for the pump through the grommet and connect to terminal T6.

Connect the loose end of the ground wire to a common ground point on your boat's distribution panel. Next connect the loose ends of the pump wire to the pump through the size fuse recommended by the pump manufacturer.

Install the electronic water sensor in a suitable location in the bilge using the long stainless self-tapping screw provided. The stainless probes should point down. Connect the loose ends of the electronic sensor wires to terminals T1 and T3 (polarity is not important).

Connect the +12VDC wire from terminal T4 to your +12VDC distribution point only after all the other connections have been made and checked carefully. When you make this last connection the EFS10 will beep once and the power-on LED will light. If any changes have to be made, disconnect the +12VDC wire at the distribution point first.