

Calibrating The Rode Counter (Ft/M/Fa)

With the anchor in the fully UP position, press the **+** key for 10 seconds to zero the display. Let out a pre-measured and marked amount of chain. The larger the amount of chain deployed, the more accurate the calibration will be. A number will show on the display. Do not clear the display. While this number is being displayed, turn OFF the power to the CH55. Reapply power while holding down the **+** key (hold for at least three seconds). The previous value will again be displayed.

Do not clear the display but use the **▲** and **▼** keys to make the previously displayed number read the correct value in Feet, Meters, or Fathoms. Press the **+** key for 1/2 second to save the new calibration value into the memory.

Installing the Magnet

Before starting the installation, please read the entire installation procedure for the magnet, sensors and instrument head.

Epoxy the magnet in one of the thicker "knuckles" of the chain wheel as shown in Figure 1. The "polarity" (North or South pole) is not important. Cover the magnet with a thin coat of sealant as a moisture seal.

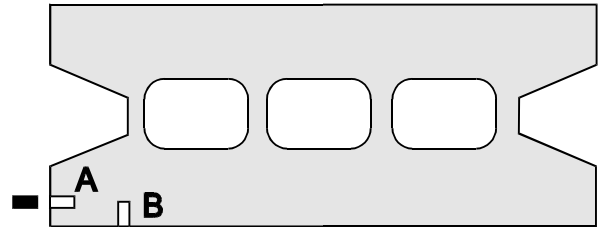

Drill 13/64" (5.5mm) diameter hole, 1/4" (7mm) deep in location A or B depending upon sensor placement

Figure 1 - Chainwheel Magnet Placement

Operation

Key Functions

The **▼**, **+**, and **▲** keys are used to select what to display, backlight levels, and calibrate the instrument. After changes are made, the new information is saved to memory.



Press and hold 1/2 second, adjusts backlight intensity



Quick press, switches display between Rode and Battery Voltage mode

fabricate a bracket to position the sensors properly.

Many windlass manufacturers predrill the chain wheel and deck plate and may have prefabricated brackets and/or sensor holders available for some or all of their windlasses. Check with your windlass manufacturer for availability, location and mounting suggestions.

The sensor over which the magnet first passes when the anchor is being raised is called the "Forward" sensor, the other is referred to as the "Aft" sensor. It is not required, but recommended, that you make the white colored sensor the "Forward" sensor.

The magnet must pass over one sensor then the other and must pass within 1/4 inch (5mm) of the sensors for reliable operation as shown in Figure 2.

Figure 2

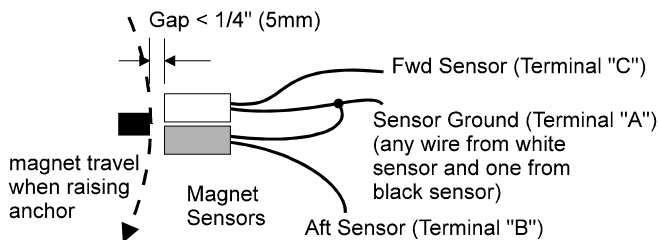

Installing the Magnet Sensors

Place the sensors right next to each other (they should touch) in a safe location so the magnet passes over one then the other sensor. If you are unable to locate the sensor in the windlass housing you may need to

Clearing The Rode Counter

With the anchor in the fully UP position, press the **+** key for 10 seconds to zero the display.

Installing the Instrument Head

- Drill a 2-1/8" (54 mm) mounting hole where you desire to mount the instrument (Figure 3).
- Bring the solenoid control lines, power, ground and sensor wires out of the mounting hole and use a

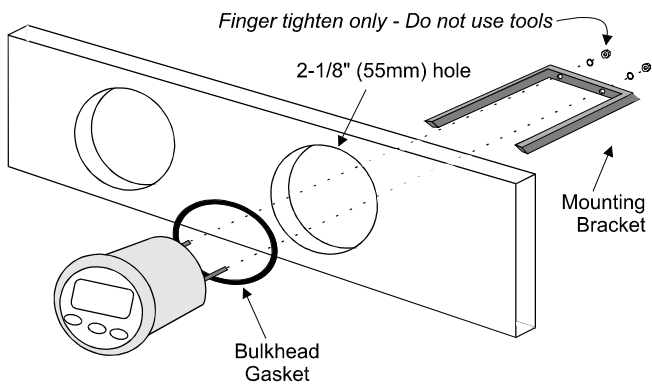

Figure 3

small flat screwdriver to make the connections to the screw terminal on the instrument case back as shown in Figures 4.

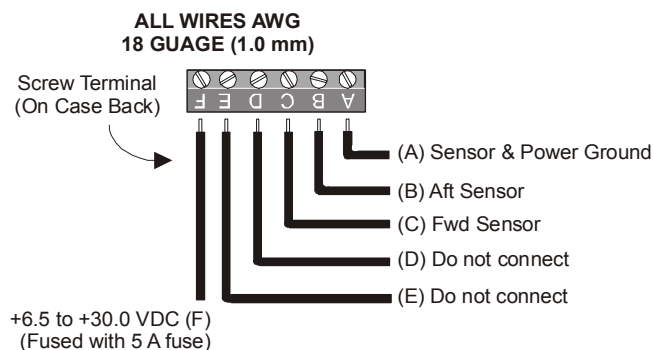

Figure 4 - Wiring Diagram